



SAFETY & TIE-BACK ANCHORS

PROBEL
SAFETY SYSTEMS ENGINEERED FOR LIFE

EXPLANATION

A fundamental concept in the use of maintenance contractor supplied conventional suspended access equipment such as bosun's chair, single work cage or platform is that **there must be two independent means of support for each worker using the equipment.**

The first means of support is the access equipment itself tied back to an anchor. The second is usually provided by a separate fall arrest system consisting of a:

- full body harness;
- lanyard (with shock absorber);
- mechanical rope grabbing device;
- lifeline;
- lifeline anchor.

In addition, anchors, which are used for tie-backs or for securing lifelines, are also an effective, practical means for directly securing a bosun's chair with descent control equipment, the most popular method of window cleaning today (direct rigging).

All Buildings Require Roof Anchors

Extract From ANSI/IWCA I-14.1 Window Cleaning Safety Standard: 4.1.1 *All buildings where window cleaning is performed that employ suspended equipment shall be equipped with roof anchorages or other approved devices which will provide for the safe use of the equipment in conformance with the provisions of this Standard.*



The chair is rigged directly to an anchor in line with the point of suspension. A separate independent anchor on the roof is required to secure the worker's fall arrest lifeline.



Bosun's chair is the equipment of choice among window cleaners. Pro-Bel safety anchors (see photo at right) are used to secure chair and separate lifeline.



Pro-Bel safety anchors may be used for securing lifeline, for tie-back of primary rigging equipment or to directly rig a bosun's chair.

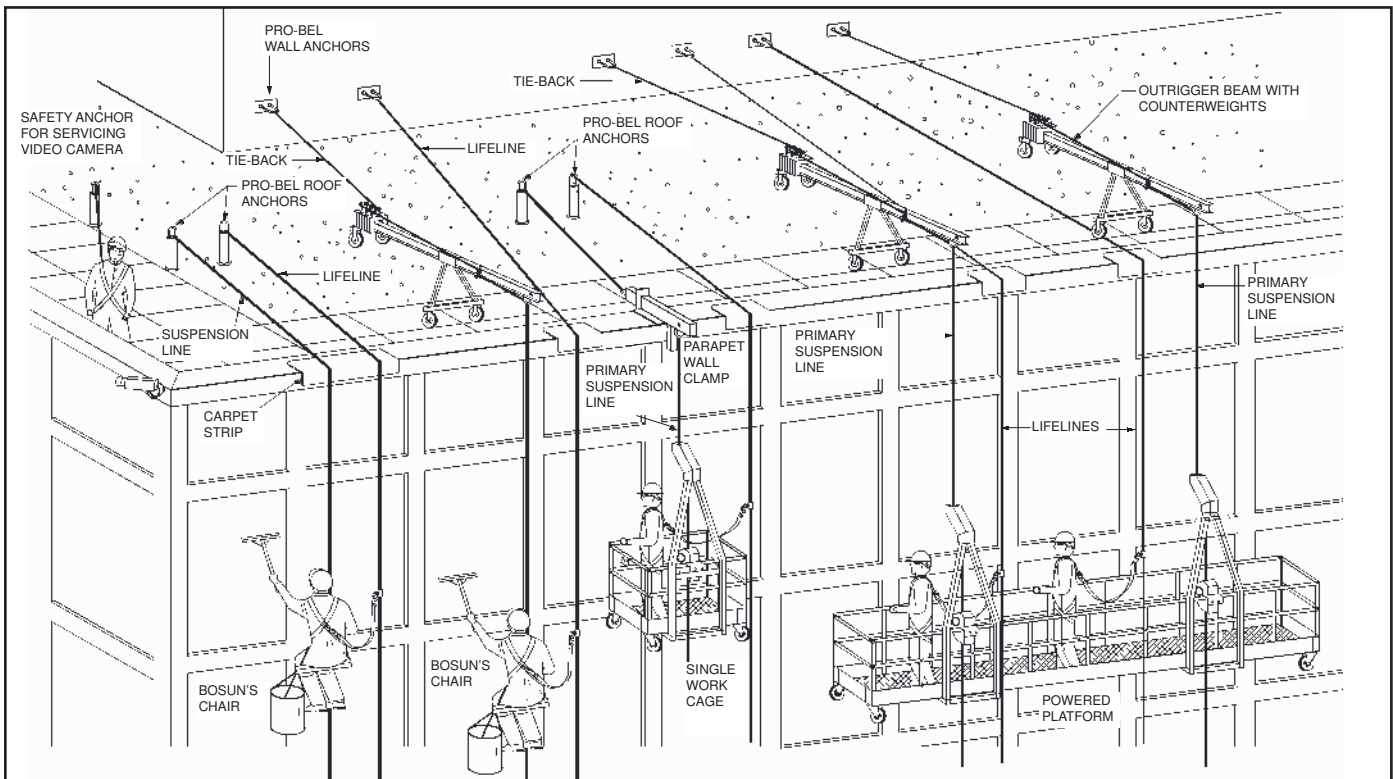

Typical rigging and fall arrest requirement scenarios using Pro-Bel safety lifeline and tie-back anchors.

DESCRIPTION

Note: Pro-Bel tie-back/lifeline anchors and direct rigging anchors are the same and are used interchangeably.

Safety Anchor Types

There are literally dozens of Pro-Bel safety anchor products available. Each has been engineered to satisfy a particular job requirement. They can be categorized as follows:

PB and PBE Series Wall Anchors

PB wall anchors are fabricated using a patented stainless steel U-bar which is detachable for ease of replacement, concrete forming and waterproofing. PBE anchors are a more economical alternative to PB anchors and are used when flashing or waterproofing is not a consideration.

PBE Series Roof Anchors

PBE Series anchors have a non-detachable stainless steel U-bar and are flashed using a spun aluminum flashing sealed at the top with a heat-shrink rubber collar flashing.

PB Series Roof Anchors

PB Series anchors, somewhat more expensive than PBE Series anchors, are fabricated using a patented stainless steel U-bar and stainless steel cap flashing which is detachable for ease of replacement.

USE

ANSI/IWCA I-14.1 (3.9 Anchorages) states that *“Building owners and window cleaning contractors shall not allow suspended work to be performed unless it has determined that the building has provided, identified and certified anchorages complying with Section 9 or 10 for: independent safety lines; tie-backs for outriggers, parapet clamps and cornice hooks; primary support anchorages for powered and manual boatswain’s chairs; primary support anchorages for rope descent systems; horizontal (rope) lines or lifelines; and wherever else required.”*



Pro-Bel PB type wall anchor in concrete wall of rooftop mechanical room.



Pro-Bel wall anchor recessed in box flashing (PB71S).



Pro-Bel PB type steel pier roof anchor with detachable cap and aluminum flashing.



Pro-Bel PBE type roof anchor with aluminum flashing and heat-shrink rubber collar flashing.



Pro-Bel roof anchor set into concrete pier (PB70).



Pro-Bel “flip-up” terrace anchor concealed with cut out core trimmed with stainless steel band and tabs.

Note Re: Alternative Finish to Galvanizing. For all anchor bases and supports, Pro-Bel offer a superior protective coating – Protex – in lieu of galvanizing if desired. Pro-Bel Protex is a 3/32" (2.4 mm) thickness, black colored, two component spray on, flexible 100% solids thermo-plastic (TPU) polyurethane/polyurea system. Protex provides exceptional impact and abrasion resistance and is factory applied via high pressure impingement mix polyurethane dispensing equipment. See Pro-Bel Protex Technical Data Sheet # R-2 for complete information.

FEATURES

All corrosion resistant materials; anchor components are stainless steel and/or hot dipped galvanized steel.

Standards conformance; all anchors comply with OSHA and ASME/ANSI/IWCA safety requirements for window cleaning, and various materials standards.

Installation flexibility; Pro-Bel safety anchors are suited to a broad range of building structures, including concrete, structural steel or precast panels. Securement methods include cast-in-place, through bolts, bolt around, welding, or chemical epoxy fastening.

Engineer certified; OSHA and ANSI/IWCA I-14.1 requires that safety anchoring devices be designed by or under the direction of a registered professional engineer experienced in such design. Pro-Bel safety anchors meet this criteria and anchor performance is based on data derived from testing and/or engineering calculations. Anchors have been tested to ensure fracture or detachment does not occur with the application of a 5,000 lb (22.2 kN) load in any direction.

Compatible with roofing; Due to stringent OSHA anchor placement requirements i.e. in line with the point of suspension and free fall distance, anchors, for the most part, must necessarily be placed on the roof. An important consideration in the design of Pro-Bel anchor products is the need to maintain the long term watertight integrity of the building. Pro-Bel products are designed with a full understanding of reliable flashing/sealing techniques to satisfy any roof condition.

Where anchors are located in waterproofed areas of a roof, a pier is normally provided to elevate the anchor above the waterproofing. In the case of metal pier anchors, the pier is supplied with the anchor and a prefabricated flashing to suit roof type as required. With concrete pier anchors, the pier must be formed, the anchor cast in, and the flashing fabricated at the job site.

Sole responsibility; Pro-Bel provides complete fall protection products/systems from concept to the supply and installation of same, including annual inspection.

Minimum anchors; OSHA and ANSI/IWCA I-14.1 requires that equipment tie-backs be "installed at right angles to the face of the building whenever possible". This requirement, can result in an unnecessary number of installed anchors. Pro-Bel has developed anchor placement chart data to help designers locate anchors to suit tie-back and lifeline requirements. This data ensures compliance with OSHA fall protection criteria while reducing the number of anchors (and roof penetrations) required.

Specific liability insurance; all Pro-Bel davit installations automatically carry \$2,000,000.00 coverage against product/system failure (over 8000 projects successfully completed to date).



Worker above uses Pro-Bel "Hands-Free" horizontal lifeline cable to safely access recessed windows as well as custom ledge-mounted Pro-Bel safety anchors (one for bosun's chair and one for lifeline) for "drops" below.

MATERIALS/FABRICATION

(as applicable)

U-bar, anchor bolts, detachable caps:

Type 304 stainless steel with yield strength of 42 Ksi (290 MPa) or mild steel to ASTM A36, Type 350W with yield strength of 43 Ksi (297 MPa), hot dipped galvanized to ASTM A123/A 123M-2000.

Hollow steel section (HSS) piers:

galvanized mild steel as above with yield strength of 50 Ksi (345 MPa), with or without urethane foam insulation.

Plate and all other sections:

galvanized mild steel as above with yield strength of 43 Ksi (297 MPa).

Seamless spun aluminum flashing (for steel pier anchors):

Type 6061-T6 alloy to ASTM B221-2006 with deck flange flashed in using felt plies to NRCA or CRCA recommendations or roofing membrane manufacturer's instructions, as applicable.

Top of anchor sealing (for steel pier anchors):

torch applied heat-shrink rubber collar flashing or detachable U-bar complete with stainless steel watertight cap.

Bolts, nuts and washers:

Type 304 stainless steel or galvanized steel to ASTM A325.

Note: Illustrated on the next few pages are only some of the many model variations of anchor products available. Anchors can be engineered to satisfy virtually any access requirement.



Pro-Bel wall anchor bolted to steel beam supporting rooftop AC chiller unit.



Window cleaners preparing to launch a contractor supplied platform over a parapet wall using Pro-Bel davits with rotating heads. Steel cables are used to suspend the platform while workers are tethered to independent Pro-Bel roof anchors with rope lifelines.



Terrace application shows how a series of Pro-Bel stainless steel “flip-up” anchors can be completely concealed with pavers when not in use. Anchors are arranged to suit both bosun’s chair and suspended platform applications.



Series of Pro-Bel wall anchors bolted to structural concrete parapet, used to secure a bosun’s chair suspension line and workers’ lifeline (interchangeable).

TESTING*

Testing of Pro-Bel wall and roof anchors involve a variety of both shop and on-site test methods including static, dynamic and destructive procedures. All testing is carried out by independent testing agencies or under the direction of a professional engineer in accordance with recognized standards.

Anchors secured using epoxy adhesive are tested to 5000 lbs (22.2 kN) to ensure against failure. The photos on this page provide an overview of Pro-Bel test procedures.

* Test data available upon request.



The *static* load test in the above photo, which applies force using a heavy duty cable come-along, was conducted to show that Pro-Bel wall and roof anchors comply with standards that require the anchors be capable of resisting without fracture and/or pull-out a force of 5000 lbs (22.2 kN). A similar test is performed on-site to verify strength of epoxy adhesive roof anchors.



Pro-Bel wall anchors secured to structural concrete using epoxy adhesive are load tested on-site using a hydraulic pull tester to verify strength and anchor bolt integrity.



Photo shows 8'-0" (2440 mm) high apparatus used for *shock (drop)* testing of Pro-Bel safety U-Bar anchors. A 220 lb. (100 kg) weight was connected to the anchor using a steel test lanyard and dropped a distance of 4'-0" (1220 mm). A series of anchors employing different securements were tested and peak forces up to 18,522 lbs (8400 kg) were generated without fracture to any part of the anchors.

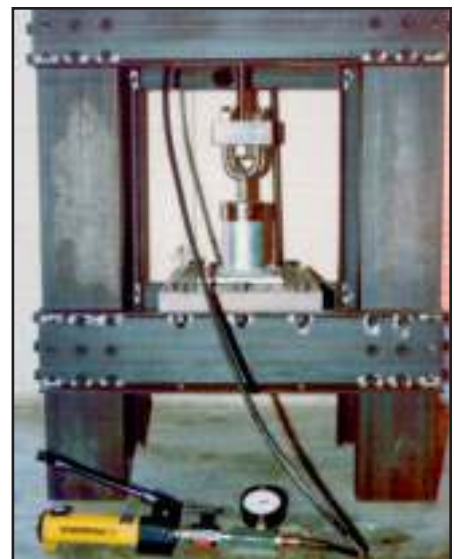

A series of Pro-Bel safety U-Bar anchors were tested to determine their *ultimate strength* (destructive testing). The force used to break the test specimens was provided by a hydraulic system, a hooking mechanism, and support structure. The highest pressure recorded just before a specimen was broken in this series of tests measured 32,445 lbs (4500 psi * 7.210 in²).

WALL ANCHOR SECUREMENTS

THROUGH-BOLT

Anchors are designed to a maximum fall arresting force of typically 1800 lbs (8.0 kN) when wearing a body harness with a safety factor of 2 without any permanent deformation and to 5000 lbs (22.24 kN) against fracture or detachment.

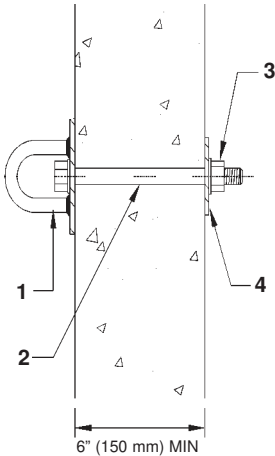

PRO-BEL MODEL # PB71S:

1. STAINLESS STEEL U-BAR SAFETY ANCHOR;
2. STAINLESS STEEL OR GALVANIZED BOLT;
3. HEAVY DUTY HEX NUT & LOCK WASHER;
4. GALVANIZED STEEL BACK PLATE.

CAST-IN-PLACE

Anchors are designed to a maximum fall arresting force of typically 1800 lbs (8.0 kN) when wearing a body harness with a safety factor of 2 without any permanent deformation and to 5000 lbs (22.24 kN) against fracture or detachment.

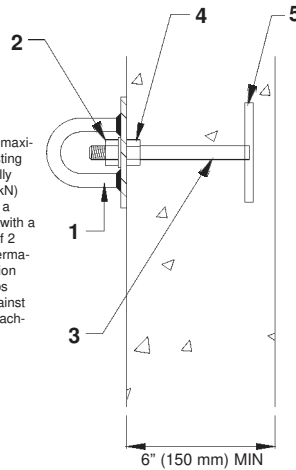

PRO-BEL MODEL # PB69S:

1. STAINLESS STEEL U-BAR SAFETY ANCHOR;
2. S.S. LOCK WASHER AND NUT
3. STAINLESS STEEL CAST-IN-PLACE ROD;
4. FORMING NUT.
5. GALVANIZED STEEL BACK PLATE.

EPOXY ADHESIVE BOLTS

Anchors are designed to a maximum fall arresting force of typically 1800 lbs (8.0 kN) when wearing a body harness with a safety factor of 2 without any permanent deformation and to 5000 lbs (22.24 kN) against fracture or detachment.

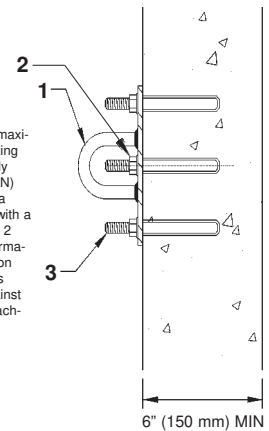

PRO-BEL MODEL # PB48S:

1. STAINLESS STEEL U-BAR SAFETY ANCHOR;
2. LOCK WASHER AND NUT;
3. EPOXY ADHESIVE ANCHOR BOLTS

REINFORCED WALL ANCHOR WITH EPOXY ADHESIVE BOLT SECUREMENT AT FLOOR

Anchors are designed to a maximum fall arresting force of typically 1800 lbs (8.0 kN) when wearing a body harness with a safety factor of 2 without any permanent deformation and to 5000 lbs (22.24 kN) against fracture or detachment.

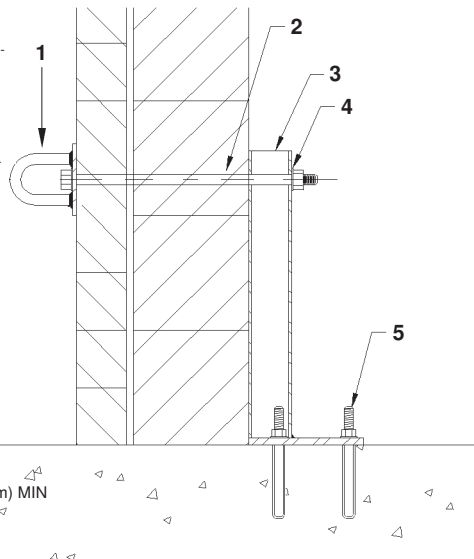
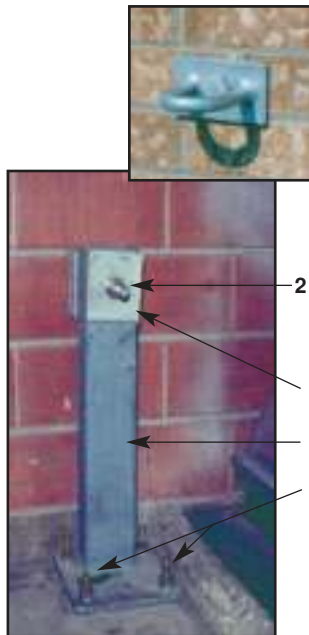

PRO-BEL MODEL # PB93S-A

1. STAINLESS STEEL U-BAR SAFETY ANCHOR;
2. S.S. OR GALVANIZED BOLT, EXPOSED THREADS TO BE DEFORMED AFTER INSTALLATION;
3. STEEL REINFORCING c/w STEEL BASE PLATE TO SUIT;
4. HEAVY DUTY HEX NUT & LOCK WASHER;
5. EPOXY ADHESIVE ANCHOR BOLTS.

RECESSED, CAST-IN-PLACE

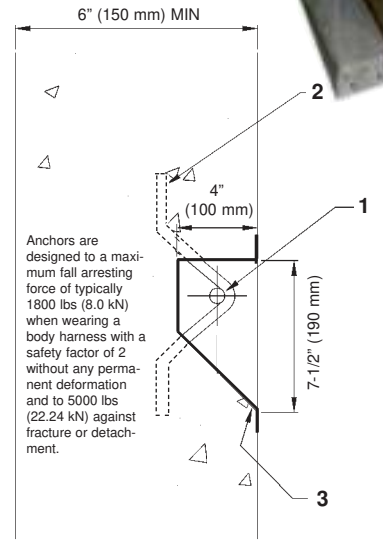

PRO-BEL MODEL # PBE68:

1. REINFORCING ROD TIES BY OTHERS;
2. STAINLESS STEEL RECESSED BOX TYPE SAFETY ANCHOR;
3. S.S. FORM NAILING FLANGE

ROOF ANCHOR SECUREMENTS

THROUGH-BOLT

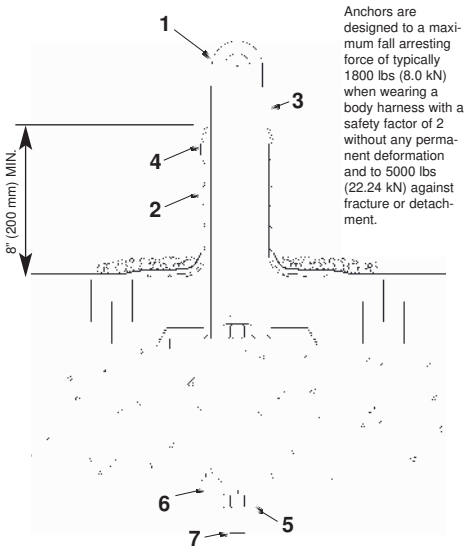

Anchors are designed to a maximum fall arresting force of typically 1800 lbs (8.0 kN) when wearing a body harness with a safety factor of 2 without any permanent deformation and to 5000 lbs (22.24 kN) against fracture or detachment.

PRO-BEL MODEL # PB73-SDC1:

1. STAINLESS STEEL U-BAR SAFETY ANCHOR;
2. SEAMLESS SPUN ALUMINUM FLASHING;
3. GALVANIZED STEEL PIER;
4. HEAT SHRINK RUBBER COLLAR FLASHING;
5. STAINLESS STEEL HEAVY DUTY HEX NUT & LOCK WASHER;
6. GALVANIZED STEEL BACK PLATE;
7. S.S. TREADED ROD

CAST-IN-PLACE

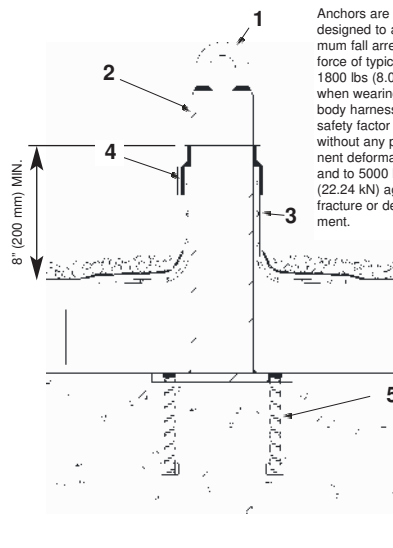

Anchors are designed to a maximum fall arresting force of typically 1800 lbs (8.0 kN) when wearing a body harness with a safety factor of 2 without any permanent deformation and to 5000 lbs (22.24 kN) against fracture or detachment.

PRO-BEL MODEL # PBE74-00A4-S:

1. STAINLESS STEEL U-BAR SAFETY ANCHOR
2. GALVANIZED STEEL PIER c/w BASE PLATE;
3. SEAMLESS SPUN ALUMINUM FLASHING;
4. HEAT-SHRINK RUBBER COLLAR FLASHING;
5. STAINLESS STEEL BOLTS c/w PLATES WELDED TO BOLTS.

EPOXY ADHESIVE BOLT

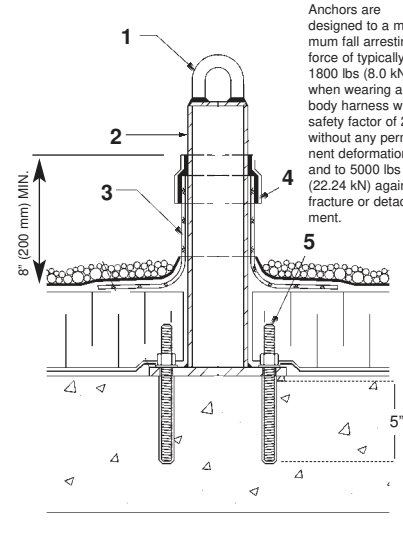

Anchors are designed to a maximum fall arresting force of typically 1800 lbs (8.0 kN) when wearing a body harness with a safety factor of 2 without any permanent deformation and to 5000 lbs (22.24 kN) against fracture or detachment.

PRO-BEL MODEL # PBE78-S:

1. STAINLESS STEEL U-BAR SAFETY ANCHOR;
2. GALVANIZED STEEL PIER c/w BASE PLATE;
3. SEAMLESS SPUN ALUMINUM FLASHING;
4. HEAT-SHRINK RUBBER COLLAR FLASHING;
5. EPOXY ANCHOR BOLTS.

WELDMENT

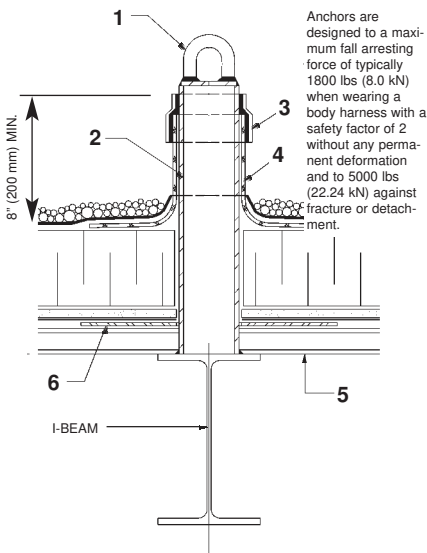

Anchors are designed to a maximum fall arresting force of typically 1800 lbs (8.0 kN) when wearing a body harness with a safety factor of 2 without any permanent deformation and to 5000 lbs (22.24 kN) against fracture or detachment.

PRO-BEL MODEL # PBE75-S:

1. STAINLESS STEEL U-BAR SAFETY ANCHOR;
2. GALVANIZED STEEL PIER;
3. HEAT-SHRINK RUBBER COLLAR FLASHING;
4. SEAMLESS SPUN ALUMINUM FLASHING;
5. EXISTING METAL DECK;
6. FLAT STOCK DECK CLOSURE PLATE (OPTIONAL)

WRAPPING I-BEAM

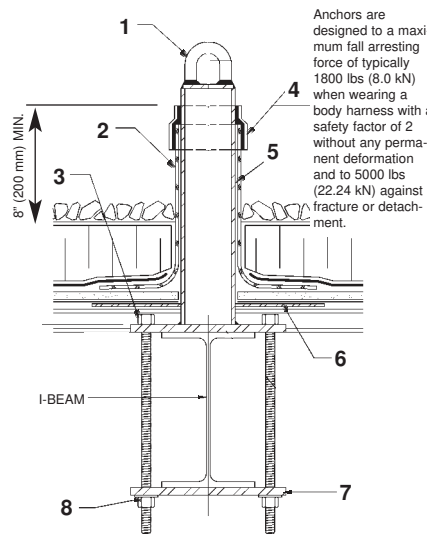

Anchors are designed to a maximum fall arresting force of typically 1800 lbs (8.0 kN) when wearing a body harness with a safety factor of 2 without any permanent deformation and to 5000 lbs (22.24 kN) against fracture or detachment.

PRO-BEL MODEL # PBE76-S:

1. STAINLESS STEEL U-BAR SAFETY ANCHOR;
2. GALVANIZED STEEL PIER c/w BASE PLATE;
3. GALVANIZED STEEL BOLTS;
4. HEAT-SHRINK RUBBER COLLAR FLASHING;
5. SEAMLESS SPUN ALUMINUM FLASHING;
6. EXISTING METAL DECK
7. FLAT STOCK DECK CLOSURE PLATE (OPTIONAL);
8. STEEL BACK PLATE;
9. HEAVY DUTY HEX NUT & LOCK WASHER.

WRAPPING CONCRETE JOIST

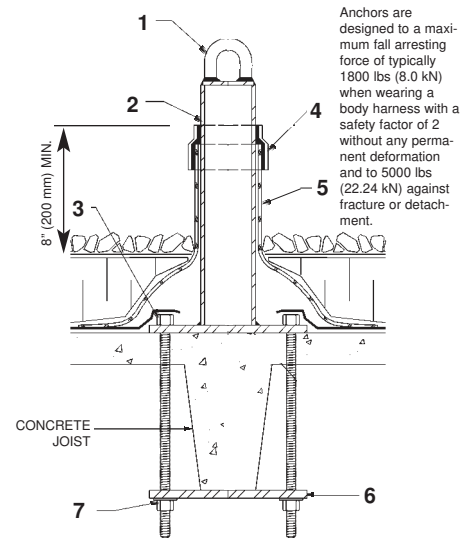

Anchors are designed to a maximum fall arresting force of typically 1800 lbs (8.0 kN) when wearing a body harness with a safety factor of 2 without any permanent deformation and to 5000 lbs (22.24 kN) against fracture or detachment.

PRO-BEL MODEL # PBE76-S:

1. STAINLESS STEEL U-BAR SAFETY ANCHOR;
2. GALVANIZED STEEL PIER c/w BASE PLATE;
3. GALVANIZED STEEL BOLTS;
4. HEAT-SHRINK RUBBER COLLAR FLASHING;
5. SEAMLESS SPUN ALUMINUM FLASHING;
6. STEEL BACK PLATE;
7. HEAVY DUTY HEX NUT & LOCK WASHER.

PRO-BEL MODEL # PB96-RP2 "FLIP-UP" ROOF ANCHOR

Anchors are designed to a maximum fall arresting force of typically 1800 lbs (8.0 kN) when wearing a body harness with a safety factor of 2 without any permanent deformation and to 5000 lbs (22.24 kN) against fracture or detachment.

NOTE: WHEN THE ANCHOR IS COMPLETELY RECESSED BELOW THE PAVER, THE PAVER CAN BE CORED OUT AND THE CORE CAN BE USED AS A CAP.



Anchor in terrace deck. Paver cutout conceals anchor when not in use.

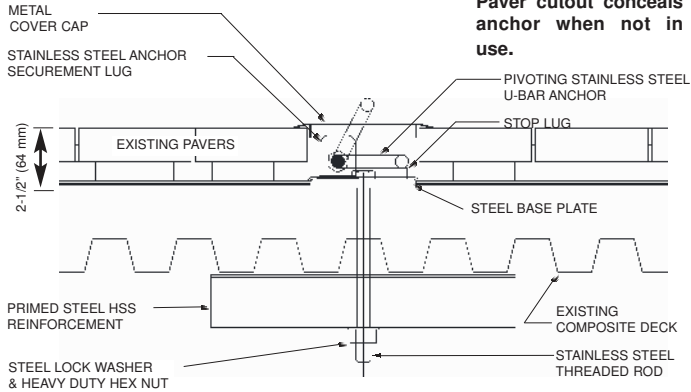

Application

Recommended for use in new construction or retrofit applications where it is necessary or desirable to conceal the anchor when not in use i.e. terrace, balcony or roof deck locations. Pro-Bel flip-up and recessed anchors are designed to suit all roof conditions including cast-in-place and weldment applications.

PRO-BEL MODEL # PB97 HEAVY DUTY DETENT-TYPE CONCRETE EMBED ANCHOR

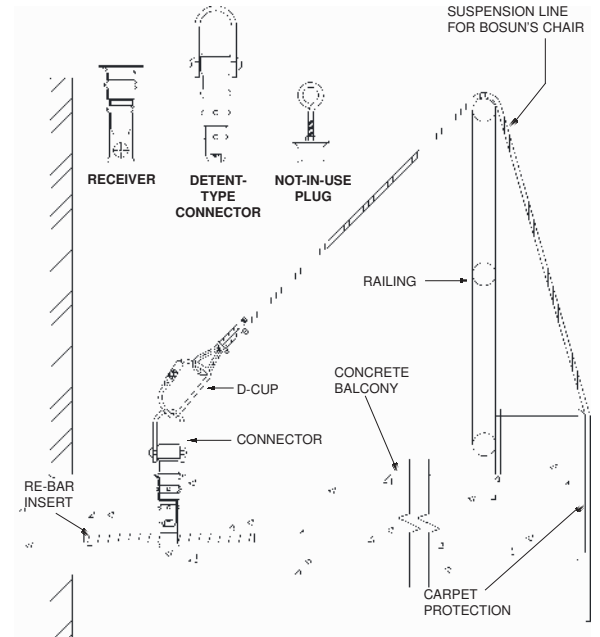

Application

Ideal for use in new construction for exposed concrete balconies where it is desirable to directly rig a bosun's chair over a balcony rail. If the rail cannot accommodate the loads, outrigger beams may be employed for exterior maintenance using a ground rigged platform. The embed anchor (connector) is removed and capped flush when not in use.

PRO-BEL ROOFTOP SUPPORTS

Pro-Bel also manufactures a complementary line of rooftop supports for pipes, satellite dishes, catwalks, cellular towers, antenna, guy wire securement, air conditioning units and similar equipment. These supports can be supplied as stand alone items or combined with U-bar safety anchors and are secured and flashed in using the same reliable methods employed for Pro-Bel anchors. For further information contact a Pro-Bel representative.



Pro-Bel galvanized steel pipe support complete with U-Bar safety anchor.

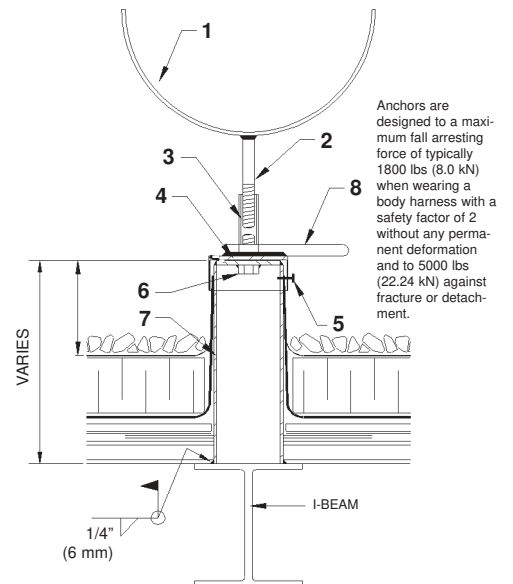

PRO-BEL MODEL # PB75-HP1 PIPE SUPPORT:

1. GALV. STEEL PIPE SADDLE;
2. THREADED GALV. ROD;
3. GALV. ROD DRILLED & TAPPED;
4. GALV. ANCHOR CAP;
5. TAMPERPROOF PIN;
6. SUPPORT BASE SECUREMENT BOLT;
7. GALV. STEEL SUPPORT BASE;
8. S.S. OR GALV. U-BAR SAFETY ANCHOR.

Anchors are designed to a maximum fall arresting force of typically 1800 lbs (8.0 kN) when wearing a body harness with a safety factor of 2 without any permanent deformation and to 5000 lbs (22.24 kN) against fracture or detachment.

DESIGN CONSIDERATIONS

Roof Space: Conventional (non-permanent) outrigger beams employing counterweights, when used with descent controlled bosun's chair, single work cage or platforms are normally supported to clear a low non-structural parapet wall. Conventional outrigger beams are typically 12'-0" to 15'-0" (3658 mm to 4572 mm) long and have a reach of 3'-0" (915 mm) or less beyond the roof edge. They require sufficient space on the roof to accommodate the inboard portion of the beam and the tie-back.

Parapet Strength: If the parapet wall is structurally sufficient, a parapet wall clamp may be secured to the wall for the suspension of access equipment.

Also, a bosun's chair can be directly secured to a safety anchor. This is known as direct rigging. The chair is rigged directly to wall or roof anchors in line with the point of suspension, and the primary synthetic rope suspension lines are normally protected at the parapet using contractor supplied carpet or other anti-abrasion protection devices.

When the parapet is not capable of supporting the applied loads, primary suspension support equipment such as outrigger beam dollies or davits must be considered. ■ See **Pro-Bel Outrigger Beam Systems** or **Davit Systems** literature.

Parapet Height: Anchors can be installed in parapet walls provided walls meet the following criteria:

1. Wall is 42" (1067 mm) minimum guardrail height;
2. Wall has been engineered to take the applied loads.

Structural loads: Anchors are designed to a maximum fall arresting force of typically 1800 lbs (8.0 kN) when wearing a body harness with a safety factor of 2 without any permanent deformation and to 5000 lbs (22.24 kN) against fracture or detachment.



Pro-Bel portable outrigger with beam dolly is ideal for clearing non-structural parapet. Note separate pier-type safety anchors for securing lifelines. See Pro-Bel Outrigger Beam Systems literature.

Location of Lifeline Anchors: The location of lifeline anchors relative to tie-back anchors must be such that a worker can neither fall more than 6'-0" (1.8 m), nor contact any lower level (OSHA 1910.66, Subpart F and ANSI/IWCA I-14.1, section 9.2.2 (g) 2). See Layout data on page A-12.

Free Design Service: The selection of window cleaning equipment is a performance oriented and highly specialized field requiring an in-depth knowledge of Rigging Methods, Safety and OSHA Standards/State Codes. Pro-Bel provides a free design service to ensure that Pro-Bel systems are properly specified.



Pro-Bel portable aluminum ground rigged davit arms are ideal for clearing non-structural parapets or reaching out past building face obstructions. See Pro-Bel Davit Systems literature.



This photo shows a Pro-Bel roof anchor installation. Anchors are welded to structural steel before a horizontal lifeline cable system is installed to provide fall protection on this arched roof.

ANCHOR LAYOUT PROCEDURE

1. Review the **Pro-Bel System & Equipment Introduction literature (pages G-6 to G-18)**. This data provides an overview of the various equipment options used to clean windows or perform other suspended building maintenance.
2. Identify all roof levels. Mark window locations on other areas requiring access on the architectural roof plan drawing(s).
3. Examine building section drawings to assess construction of parapet wall, mechanical room wall and roof assembly or other building elements as necessary.
4. Examine roof structural drawings for possible anchorage locations.
5. Examine building elevations or other drawings to identify any setbacks, recesses or other unusual features.
6. Review the Design Considerations on page A-10 to assist in making a "rigging" decision.
7. If it has been determined that "rigging" is suited to using anchors only, for both the support of primary suspension equipment and lifelines, refer to Anchor Spacing Chart at right on page A-12.

Note: Primary suspension equipment refers to conventional, maintenance contractor supplied equipment i.e. bosun's chair, transportable outrigger beams, single work cage, temporary platform and parapet wall clamps.

ANCHOR PLACEMENT

1. After determining what areas of the building face will need to be accessed for maintenance, anchor locations can now be chosen.
2. Anchors are located on the roof of the building and are generally secured to any or all of the following acceptable vertical or horizontal elements: mechanical room curb walls; parapet walls minimum 42" (1067 mm) high; roof mounted structural elements e.g. rooftop equipment structural support beams or columns, and similar structures; roof decks (to concrete slab, precast deck, structural steel, and similar structures); finished roof top terraces.
3. Ideally locations for Pro-Bel safety anchors are in direct line with the anticipated "drops" and are suited to both bosun's chair and suspended platform. A "drop" for a chair is typically a 6'-0" (1830 mm) wide area, and 20'-0" to 28'-0" (7000 mm to 8535 mm) for a platform. Two anchors are required for bosun's chair (1 primary and 1 lifeline) and 4 anchors are required for a platform (2 primary and 2 lifeline).

4. Lifeline anchors and primary tie-back anchors for transportable outrigger beams and parapet wall clamps should be located in line with the point of suspension (perpendicular) whenever practical, but should not be offset more than 10'-0" (3084 mm) measured horizontally from running at a right angle to the building face at the point of suspension. The angle created by the offset distance should not exceed 25°. See anchor spacing chart data on page A-12.
5. If a bosun's chair or similar single point suspension equipment is used with the primary support lines directly attached to anchors (direct rigging), the horizontal portion of the descent line (that portion of the support from the anchor to the roof edge) should be in a plane at right angles to the face of the building at the "drop". This guideline will ensure that slide distance and swing action in the event of a fall will be reduced to a reasonably safe minimum thereby lessening the potential for worker collision injury, while allowing for self-recovery.

Essentially, OSHA 1910.66, Subpart F and ANSI/IWCA I-14.1, section 9.2.2 (g) 2 requires personal fall arrest systems be rigged such that an employee can neither free fall more than 6'-0" (1.8 m), nor contact any lower level. Any anchor placement scenario should reflect this requirement.

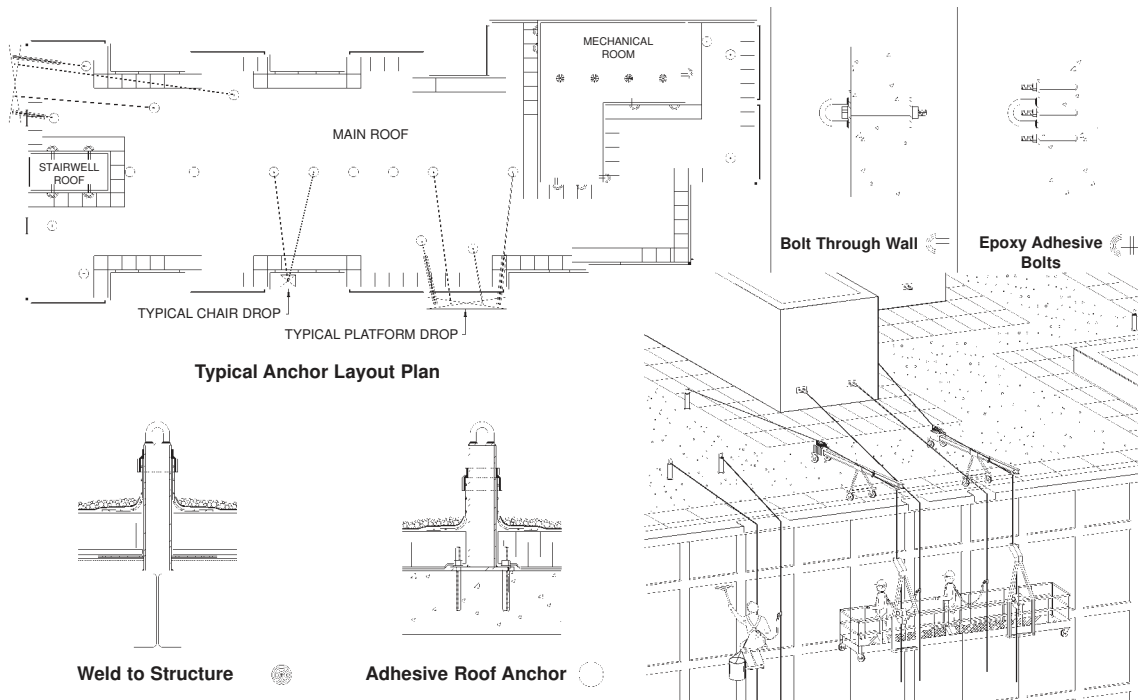

ROOF PLAN / ANCHOR LAYOUT SHOWING TYPICAL CHAIR AND PLATFORM DROPS

ANCHOR PLACEMENT (continued)

6. Locate the very first roof anchor, which should be a primary suspension or tie-back anchor. If the parapet wall is less than 42" (1067 mm) guardrail height, this anchor should be a minimum of 6'-0" (1830 mm) distance from the parapet so that the worker can tie off whenever the worker has to step within 6'-0" (1830 mm) of an unguarded edge. If the parapet is minimum 42" (1067 mm) high, the anchor can be located any distance inside the parapet.
7. The second and subsequent primary suspension or tie-back anchors can now be located as per item 3.
8. After primary anchors have been located, lifeline anchors can now be located relative to the primary anchors using the anchor spacing chart data at right.
9. Anchor spacing must be adjusted, of course, to circumvent any obstruction.



Pro-Bel roof anchors welded to beams before steel deck is installed.

Note: Pro-Bel tie-back/lifeline anchors and direct rigging anchors are the same and are used interchangeably.

RELATIVE SPACING BETWEEN PRIMARY SUSPENSION ANCHOR AND LIFELINE ANCHOR

The anchor spacing data shown below indicates recommended spacing of fall arrest safety anchors relative to primary suspension or tie-back anchors.

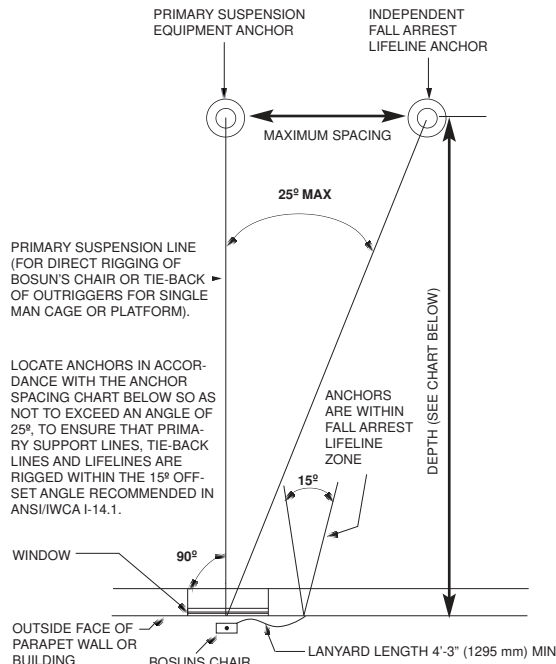

This narrow roof area requires anchors on 5'-0" (1830 mm) centers. See Anchor Spacing Chart below.

Plan View of Roof Showing Rigging In Line with Anchors

ANCHOR SPACING CHART

DEPTH		MAXIMUM SPACING	
U.S./Imperial	Metric (mm)	U.S./Imperial	Metric (mm)
21'-5"	6528	10'-0"	3048
19'-4"	5893	9'-0"	2743
17'-2"	5232	8'-0"	2438
15'-1"	4597	7'-0"	2134
12'-11"	3937	6'-0"	1829
10'-8"	3251	5'-0"	1524

When rigging primary lines, tie-back lines and lifelines for a bosun's chair, single work cage or platform, there are many scenarios having an influence on whether lines are anchored in line with or offset from the point of suspension. Ultimately, the object is to place the anchors in a manner that will suit chair and platform locations within the variable work zones while ensuring that the OSHA maximum free fall distance of 6'-0" (1.8 m) is not exceeded, in

the event of a worker falling. Recognizing this, Pro-Bel employ a 25° angle placement criteria for the location of both primary support lines and secondary lifelines. This criteria will ensure that lines are rigged within 15° of the point of suspension in accordance with the ANSI/IWCA I-14.1 Window Cleaning Safety Standard.

RELATED DATA

For general data relating to all Pro-Bel products and services e.g. codes, installation, warranty, etc., refer to the Pro-Bel System & Equipment Introduction literature (pages G-2 to G-32). For product data relating to other fall protection systems and primary suspension equipment, see other Pro-Bel literature.



Pro-Bel PBE Series roof anchors installed in single ply roof.

EXAMPLE INSTALLATION – RETROFIT ROOF ANCHOR



1. Small area of roof covering is removed down to concrete deck.



2. Holes are drilled into or through concrete deck to accommodate roof anchor bolts.



3. Anchor is installed using either bolt-through or chemical adhesive securement depending on access from below.



4. Watertight integrity of roof is restored using spun aluminum flashing and new roof covering (roof patch). Photo shows protected membrane roof.



5. Top of spun aluminum flashing is sealed to steel anchor using a conformable mastic tape and heat-shrink rubber collar flashing.



6. Close-up of anchor. Installation method is similar for both conventional roof (membrane above insulation) and protected membrane roof (membrane below insulation).

OTHER USES

Generally, Pro-Bel window cleaning/suspended maintenance anchor systems are economical or practical for all new or retrofit buildings 3 stories and higher where windows or building facades are accessed from the roof.

In addition to window cleaning applications, Pro-Bel safety anchor systems are recommended for work such as:

- construction, restoration, cleaning, sandblasting, caulking, or pointing;
- fall protection for ladder work using full body harness and lanyard; and
- interior or exterior industrial applications wherever maintenance personnel are exposed to falls from elevation.

Pro-Bel safety anchor systems are compatible with all types of suspended maintenance equipment and can be used interchangeably for either tying off suspended equipment or fall protection life-lines.

BUILDING OWNER ASSURANCE

There is a shared responsibility between the building owner and the window cleaning/suspended maintenance contractor (employer). OSHA and ANSI/IWCA I-14.1 acknowledges that the building owner is the controlling influence and must assure the contractor that the system has been installed in accordance with engineered drawings, test data (when required), and equipment specifications. The building owner shall provide written assurance that the installation has been annually inspected and maintained to ensure that all equipment is safe and operating as required.

 Refer to Pro-Bel "Digest for Building Owners, Property Managers, and General Contractors" literature for more detailed information.



AVAILABILITY & COST

Pro-Bel window cleaning/suspended maintenance safety systems are distributed throughout the United States, Canada and internationally.

Budget pricing is provided on a project-to-project basis for both materials and installation, or materials only. See "Technical Consultation" at right.

FREE DESIGN SERVICE

The selection of window cleaning equipment is a performance oriented and highly specialized area. Also the issues of fall protection and fall arrest are serious concerns with OSHA inspection authorities. Interpreting the myriad OSHA standards, including the separate requirements of various states, and proposed changes, is a daunting task at best.

Each building is different, requiring an individual technical approach and a time commitment beyond the scope of most professional offices. Even with a high degree of knowledge and the best of intentions, the planning process can go askew. It is for these reasons that Pro-Bel provides architects and engineers with a FREE DESIGN SERVICE, and to ensure that Pro-Bel Window Cleaning/Suspended Maintenance Systems are properly specified and installed.

TECHNICAL CONSULTATION

Pro-Bel Group Ltd. provides a complete technical consultation service, available to architects, consultants, engineers, contractors, and building owners. Without obligation, Pro-Bel will provide interested parties with a proposed window cleaning/suspended maintenance design concept to OSHA requirements, including anchor and equipment locations, securement, roofing details and specifications.

Simply provide the following information:

- roof plans (architectural & structural);
- building elevations;
- typical floor plans
- section drawings showing parapet walls or roof edge condition and mechanical room walls; and
- any other drawings pertinent to window cleaning/suspended maintenance requirements.

Pro-Bel will review drawings and provide one or more concepts as required with respect to equipment, tie-back methods and similar options.

In addition, Pro-Bel Group Ltd. will provide budget pricing for window cleaning/suspended maintenance systems contingent upon design acceptance between Pro-Bel and architect/owner for the proposed project.

PRO-BEL PB-00 AND PB-01 STAINLESS STEEL BREAKAWAY ANCHORS FOR STEEL ROOFS
(Safety Anchor and/or Horizontal Lifeline Support)

NOTE: NO CUTTING OR WATERPROOFING REQUIRED

OPTIONAL POST HEADS INCLUDE ANCHOR EYE, STANDARD RUNNER, AND REVERSIBLE RUNNER

PB-01 SAFEST SOLUTION FOR OLD STEEL ROOFS FIXED TO METALLIC FRAMEWORK

PB-00 UNIVERSAL SOLUTION FOR NEW STEEL ROOFS, NO MATTER THE FRAMEWORK

Application (Breakaway Concept)
In a fall arrest situation, a breakaway mechanism is activated at a pre-determined point e.g. 617 lbs (280 kg). A built-in energy absorbing device ensures the anchorage will hold in case of a fall. Concept substantially reduces load applied to securement screws.

SPECIFICATION

SPEC NOTE: This basic guide specification (Section 11 24 23 - Window Washing Systems) is devoted exclusively to safety and tie-back anchors and is written in accordance with the CSI/CSC Three Part Section Format. It must be adapted to suit the requirements of individual projects. If other equipment such as outrigger beams, davits, monorails, horizontal cable lifelines or other equipment is required, refer to appropriate Pro-Bel literature and incorporate materials and/or other clauses as required. Square brackets [] indicate choice, alternatives, data required or need for the specifier to make a decision.

PART 1 - GENERAL

- 1.01 General Requirements
- A. Comply with the conditions of the Contract and Division 1 - General Requirements.
- 1.02 Section Includes
- A. Work of this section includes the design, supply and installation of window cleaning/suspended maintenance equipment.
- 1.03 Related Sections
- A. Section [01 31 19 – Project Meetings]
B. Section [01 61 00 – Common Product Requirements]
C. Section [01 74 00 – Cleaning and Waste Management]
D. Section [03 30 00 - Cast-in-Place Concrete: concrete runway, piers and sleepers for roof cars].
E. Section [05 05 23 - Metal Fastenings: horizontal lifeline fasteners].
F. Section [05 50 00 - Metal Fabrications: monorail and davit system cantilevered support brackets].
G. Section [07 62 00 - Sheet Metal Flashing and Trim: aluminum flashing for davit bases].
H. Section [08 31 13 - Access Doors and Frames: rigging access doors in walls].
I. Section [08 44 00 - Curtain Wall and Glazed Assemblies: mullion and stabilization co-ordination].
J. Section [22 11 16 - Domestic water Piping: hot and cold water supply, faucets and drains at [every] roof level].
K. Section [26 00 00 - Electrical: climbing monorail power supply].
L. Section [26 20 00 - Low Voltage Electrical Transmission: three phase 208 volts 60 Hertz service at [every] roof level].
M. Section [26 25 00 - Enclosed Bus Assemblies: climbing monorail busbar].
N. Section [01 78 00 - Closeout Submittals].
- 1.04 References
- A. AISC 360-05 "Load and Resistance Factor Design Specification for Structural Steel Buildings".
- B. AISI SG-02KIT with 2001 Supplement "Specification for Design of Cold-Formed Steel Structural Members".
- C. Aluminum Association AA ADM-1-Aluminum Design Manual, 2000 and ANSI/AWS D1.2/D1.2M:2003 Structural Welding Code - Aluminum.
- D. ANSI/AWS D1.1/D1.1M:2008 Structural Welding Code - Steel.
- E. ANSI/IWCA I-14.1-2001 Window Cleaning Safety Standard (International Window Cleaning Association).
- 1.05 Design Requirements
- A. Design window cleaning/suspended maintenance system to suit building and in accordance with plans, specifications, standards, and regulations/codes contained in section 1.04 and 1.08.
- B. Locate safety and tie-back anchors to suit suspension equipment which will be used on the building with respect to items such as rigging, spacing, roof edge condition and similar items.
- C. Design all anchor components to provide adequate attachment to the building and suited to current window cleaning/suspended maintenance practices. Ensure compatibility with industry standard equipment.
- D. Ensure all anchor components conform to proper engineering principles and have been designed by a Professional Engineer qualified in the design of window cleaning/suspended maintenance equipment, its application and safety requirements.
- E. Design system fall arrest safety anchors to comply with the following structural requirements:
1. Fall arrest safety anchors are designed to a typical maximum fall arresting force of 1800 lbs (8.0 kN) when wearing a body harness with a factor of safety of 2 without any permanent deformation and to 5000 lbs (22.2 kN) against fracture or detachment.
- SPEC NOTE: For California State, substitute 5400 lbs (24 kN) in lieu of 5000 lbs. (22.2 kN).*
- 1.06 Shop Drawings and Engineering Certification
- A. Submit shop drawings showing complete layout and configuration of complete window cleaning/suspended maintenance system, including all components and accessories. Clearly indicate design and fabrication details, window "drops", hardware, and installation details.
- B. Shop drawings to include installation and rigging instructions and all necessary Restrictive and Non-Restrictive Working Usage Notes and General Safety Notes.
- C. Shop drawings to be reviewed by a professional engineer, and upon request, complete with test reports.
- 1.07 Qualifications
- A. Manufacturer: Work of this Section to be executed by manufacturer specializing in the design, fabrication and installation of window cleaning/suspended maintenance systems having a minimum of 5 years documented experience.
- B. Loading and safety assurance: Work of this Section to meet the requirements of governing codes and jurisdiction and to comply with properly engineered loading and safety criteria for the intended use.
- C. Insurance: Manufacturer to carry specific liability insurance (products and completed operations) in the amount of \$2,000,000.00 to protect against product/system failure.
- D. Welding to be executed by certified welders in accordance with AWS requirements.
- 1.08 Regulatory Requirements
- SPEC NOTE: Re 1.08.A. Specify for all States other than New York and California.*
- A. Comply with the following OSHA regulations:
- 1910, Subpart D (Walking and Working Surfaces).
 - Appendix C to 1910 Subpart F (Personal Fall Arrest Systems).
 - "OSHA Ruling on Window Cleaning by Bosun's Chair" Memorandum to Regional Administrators from P. K. Clark, Director, Directorate of Compliance Programs.
 - 1910.66, Subpart F (Powered Platforms).
- SPEC NOTE: Re 1.08.B and 1.08.C. Specify for New York State or California only as applicable.*
- B. Comply with the following New York State regulations:
- Department of Labor Advisory Standard 101 - Construction, Operation and Maintenance of Suspended Scaffolds Used for Window Cleaning and Light Maintenance.
 - Advisory Standard 111 - Hoisting Machines Used for Suspended Scaffolds.
 - Department of Labor Industrial Code Rule 21 - Protection of Persons Employed at Window Cleaning - Structural Requirements, Equipment and Procedures.
- C. Comply with the following California State regulation:
- Code of Regulations, Title 8 - Industrial Relations, Article 5 (Window Cleaning), Article 6 (Powered Platforms for Exterior Building Maintenance), and Appendix C to Article 6 (Personal Fall Arrest System).
- 1.09 Maintenance Data
- A. Submit 1 copy of system Equipment Manual & Inspection Log Book, with "Initial Inspection - Certification for Use" and "Inspection Sign-Off" forms completed.
- B. Submit 2 copies of a reduced plastic laminated as-built shop drawing showing equipment locations and details. This drawing is to be posted near exits onto the roof.

PART 2 - PRODUCTS

2.01 Manufacturer

- A. This specification is based on systems currently being manufactured by PRO-BEL GROUP LTD. Toll free: 1-800-461-0575. Telephone: 905-427-0616, Fax: 905-427-2545, info@pro-bel.ca.
- B. Other manufactured products meeting this specification may be substituted provided that manufacturers show proof of product insurance. Equipment details to be approved by the architect and/or consultant. Companies, such as miscellaneous metal fabricators, who are not normally engaged in the design and manufacture of window cleaning/suspended maintenance equipment are not permitted to bid.

2.02 Equipment

SPEC NOTE: List type and quantity as required.]

- A. [_____]
- B. [_____]
- C. [_____]

2.03 Materials

SPEC NOTE: Delete items not required.

- A. **Safety U-bars:** [Type 304 stainless steel with yield strength of 35 Ksi (240 MPa)] [mild steel, Type 300W with yield strength of 44 Ksi (300 MPa), hot-dip galvanized to ASTM A123/A 123M-2000]. U-bar to be not less than 3/4" (19 mm) diameter material with 1-1/2" (38 mm) eye opening.
- B. **Securement bolts:** mild steel, Type 300W with yield strength of 44 Ksi (300 MPa), hot-dip galvanized to ASTM A123/A 123M-2000.
- C. **Hollow steel section (HSS) piers:** mild steel, Type 300W with yield strength of 50 Ksi (350 MPa). Wall thickness to suit application, [hot dipped galvanized to ASTM A123/A 123M-2000] [with Pro-Bel Protex 3/16" (2.4 mm) thickness, black colored, two-component TPU polyurethane/polyurea coating system].

SPEC NOTE: Pro-Bel Protex is a superior substitute to galvanizing and provides exceptional impact and abrasion resistance.

- D. **Base plate and all other sections:** [galvanized] [Pro-Bel Protex coated] mild steel as above with yield strength of 44 Ksi (300 MPa). Thickness and securement to suit application.

SPEC NOTE: Re 2.03,E. Specify aluminum flashing for BUR or modified bitumen roofs only (membrane above or below insulation). For single ply roofs, flashing to be in accordance with membrane manufacturer's instructions. Specify conformable mastic tape and heat-shrink rubber collar flashing for EPB Series roof anchors (BUR or modified bitumen roofs) or s.s. cap for PB series roof anchors (any type roof).

- E. **Seamless spun aluminum flashing (for steel pier anchors):** Type 6061-T6 alloy to ASTM B221-2000 with deck flange flashed in to NRCA or CRCA recommendations. Seal top of aluminum flashing with [conformable mastic tape and torch applied heat-shrink rubber collar flashing] [detachable watertight stainless steel cap].
- F. **Miscellaneous bolts, nuts and washers:** mild steel, Type 300W with yield strength of 44 Ksi (300 MPa), hot-dip galvanized to ASTM A123/A 123M-2000 or Type 304 stainless steel with yield strength of 35 Ksi (240 MPa).

2.04 Fabrication

- A. General:
 - 1. Fabricate work true to dimension, square, plumb, level and free from distortion or defects detrimental to appearance and performance.
 - 2. Grind off surplus welding material and ensure exposed internal corners have smooth lines.

PART 3 - EXECUTION

3.01 Examination

- A. Examine surfaces and areas upon which the work of this Section depends. Report to the Contractor in writing, defects of work prepared by other trades and other unsatisfactory site conditions which would cause defective installation of products, or cause latent defects in workmanship and function.
- B. Verify site dimensions.
- C. Commencement of work will imply acceptance of prepared work.

3.02 Installation

- A. Install equipment in accordance with approved shop drawings and manufacturer's recommendations.
- B. Co-ordinate installation with work of related trades.
- C. Install all work true, level, tightly fitted and flush with adjacent surfaces as required.
- D. Deform threads of tail end of anchor studs after nuts have been tightened to prevent accidental removal or vandalism.

SPEC NOTE: Re 3.02,E. Specify for furnish only projects if required.

- E. Manufacturer to assist and/or supervise installation of window cleaning/suspended maintenance equipment installed by others.
- F. Structural steel to receive safety anchors to have adequate bearing surface as indicated on shop drawings and/or to ensure 100% weld.

3.03 Final Adjusting and Inspection

- A. Adjust and leave equipment in proper working order.
- B. Complete "Initial Inspection - Certification for Use" form included in Equipment Manual & Inspection Log Book.

3.04 Testing

- A. All anchors relying upon chemical adhesive fasteners to be 100% tested on site using load cell test apparatus in accordance with manufacturer's recommendations.

SERVING CANADA, THE UNITED STATES AND THROUGHOUT THE WORLD

TO FIND ADDITIONAL PRO-BEL LOCATIONS IN YOUR AREA PLEASE VISIT OUR WEBSITE...

www.pro-belgroup.com

Pro-Bel Group Ltd.
(Florida)
2501 NW 34th Place, Unit 23
Pompano Beach, FL 33069
954-457-5080 - local
866-377-6235 - toll free
954-457-9010 - fax
info@pro-belgroup.com

Pro-Bel Group Ltd.
(Chicago)
2850 West Fulton Street
Chicago, IL 60612
773-638-6714 - local
773-638-6715 - fax
info@pro-belgroup.com

Pro-Bel Group Ltd.
(Pennsylvania)
421 Guilford Avenue
PO BOX 556
Chambersburg, PA 17201
(717) 263-7400 - local
(717) 263-7414 - fax
info@pro-belgroup.com

Pro-Bel
(China)
36 Guangqumennei St.
Beijing, 100036, China
(+86.10.6718 6272 - local
(+86.10.6713 8186 - fax
(+86.139 1146 0532 - cell
www.pro-bel.com.cn

Pro-Bel Enterprises Ltd.
(India)
#26, Chamundi Mansions
22nd Main, 2nd Phase
JP Nagar Bangalore
560078
(080) 2658-7856 - local